

PCT

WORLD INTELLECTUAL PROPERTY ORGANIZATION
International Bureau



INTERNATIONAL APPLICATION PUBLISHED UNDER THE PATENT COOPERATION TREATY (PCT)

(51) International Patent Classification ⁶ : F16L 55/165	A1	(11) International Publication Number: WO 97/11306
		(43) International Publication Date: 27 March 1997 (27.03.97)
(21) International Application Number: PCT/DK96/00393	(81) Designated States: AL, AM, AT, AU, AZ, BA, BB, BG, BR, BY, CA, CH, CN, CU, CZ, DE, DK, EE, ES, FI, GB, GE, HU, IL, IS, JP, KE, KG, KP, KR, KZ, LC, LK, LR, LS, LT, LU, LV, MD, MG, MK, MN, MW, MX, NO, NZ, PL, PT, RO, RU, SD, SE, SG, SI, SK, TJ, TM, TR, TT, UA, UG, US, UZ, VN, ARIPO patent (KE, LS, MW, SD, SZ, UG), Eurasian patent (AM, AZ, BY, KG, KZ, MD, RU, TJ, TM), European patent (AT, BE, CH, DE, DK, ES, FI, FR, GB, GR, IE, IT, LU, MC, NL, PT, SE), OAPI patent (BF, BJ, CF, CG, CI, CM, GA, GN, ML, MR, NE, SN, TD, TG).	
(22) International Filing Date: 18 September 1996 (18.09.96)		
(30) Priority Data: 1039/95 19 September 1995 (19.09.95) DK		
(71)(72) Applicant and Inventor: KNUDSEN, Jens, Christian, Hangaard (DK/DK); Lokesvej 19, DK-3140 Ålsgårde (DK).		
(74) Agent: CHAS. HUDE A/S; H.C. Andersens Boulevard 33, DK-1553 Copenhagen V (DK).	Published With international search report.	

(54) Title: HYDRAULICALLY ACTUATABLE EXPANDER

(57) Abstract

The invention relates to a hydraulically actuatable expander (1) for straightening and repairing partially collapsed pipelines. In order to obtain a high straightening force, it comprises: at least one elongated cylinder housing (2) with a central longitudinal axis (7-7') and one or a plurality of cylinder bores or cylinder sleeves (8) in a single section transverse to said longitudinal axis (7-7'); a piston inserted in each cylinder bore or each cylinder sleeve (8), said piston being connected to a hydraulic channel for the expansion of expander segments (10) secured thereto, at least two synchronizing mechanisms arranged at regular intervals in the longitudinal direction of the cylinder housing and being connected to the expander segments (10) in such a manner that all said expander segments expand synchronously to the same extent, where said two synchronizing mechanisms furthermore are interconnected such that the expander segments (10) also expand to the same extent in the direction of one synchronizing mechanism

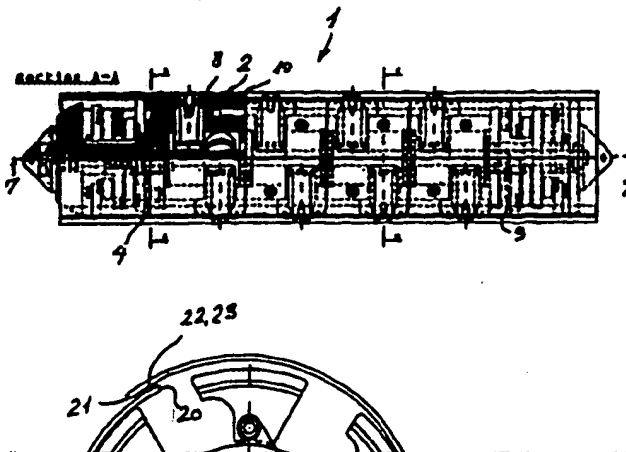

GE

@PJJL USTATUS DEVICE = ON
@PJJL USTATUS TIMED = 0

PCT

WORLD INTELLECTUAL PROPERTY ORGANIZATION
International Bureau



INTERNATIONAL APPLICATION PUBLISHED UNDER THE PATENT COOPERATION TREATY (PCT)

<p>(51) International Patent Classification ⁶ : F16L 55/165</p>	<p>A1</p>	<p>(11) International Publication Number: WO 97/11306 (43) International Publication Date: 27 March 1997 (27.03.97)</p>
<p>(21) International Application Number: PCT/DK96/00393 (22) International Filing Date: 18 September 1996 (18.09.96) (30) Priority Data: 1039/95 19 September 1995 (19.09.95) DK (71)(72) Applicant and Inventor: KNUDSEN, Jens, Christian, Hangaard (DK/DK); Lokesvej 19, DK-3140 Ålgårde (DK). (74) Agent: CHAS. HUDE A/S; H.C. Andersen Boulevard 33, DK-1553 Copenhagen V (DK).</p>	<p>(81) Designated States: AL, AM, AT, AU, AZ, BA, BB, BG, BR, BY, CA, CH, CN, CU, CZ, DE, DK, EE, ES, FI, GB, GE, HU, IL, IS, JP, KE, KG, KP, KR, KZ, LC, LK, LR, LS, LT, LU, LV, MD, MG, MK, MN, MW, MX, NO, NZ, PL, PT, RO, RU, SD, SE, SG, SI, SK, TJ, TM, TR, TT, UA, UG, US, UZ, VN, ARIPO patent (KE, LS, MW, SD, SZ, UG), Eurasian patent (AM, AZ, BY, KG, KZ, MD, RU, TJ, TM), European patent (AT, BE, CH, DE, DK, ES, FI, FR, GB, GR, IE, IT, LU, MC, NL, PT, SE), OAPI patent (BF, BJ, CF, CG, CI, CM, GA, GN, ML, MR, NE, SN, TD, TG).</p> <p>Published <i>With international search report.</i></p>	

(54) Title: HYDRAULICALLY ACTUATABLE EXPANDER

(57) Abstract

The invention relates to a hydraulically actuatable expander (1) for straightening and repairing partially collapsed pipelines. In order to obtain a high straightening force, it comprises: at least one elongated cylinder housing (2) with a central longitudinal axis (7-7) and one or a plurality of cylinder bores or cylinder sleeves (8) in a single section transverse to said longitudinal axis (7-7); a piston inserted in each cylinder bore or each cylinder sleeve (8), said piston being connected to a hydraulic channel for the expansion of expander segments (10) secured thereto, at least two synchronizing mechanisms arranged at regular intervals in the longitudinal direction of the cylinder housing and being connected to the expander segments (10) in such a manner that all said expander segments expand synchronously to the same extent, where said two synchronizing mechanisms furthermore are interconnected such that the expander segments (10) also expand to the same extent at the position of one synchronizing mechanism as at the position of the second synchronizing mechanism.

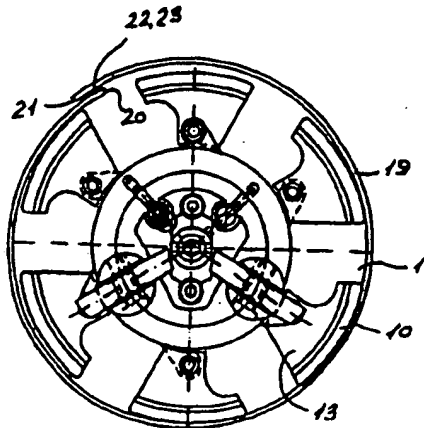
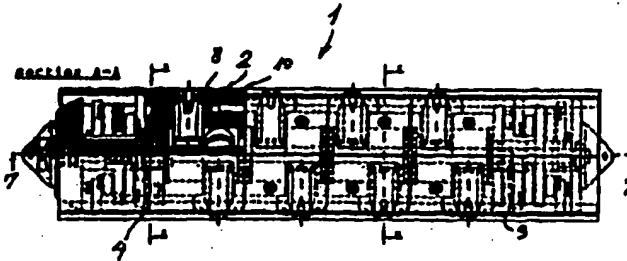

FOR THE PURPOSES OF INFORMATION ONLY

Codes used to identify States party to the PCT on the front pages of pamphlets publishing international applications under the PCT.

AM	Armenia	GB	United Kingdom	MW	Malawi
AT	Austria	GE	Georgia	MX	Mexico
AU	Australia	GN	Guinea	NE	Niger
BB	Barbados	GR	Greece	NL	Netherlands
BE	Belgium	HU	Hungary	NO	Norway
BF	Burkina Faso	IE	Ireland	NZ	New Zealand
BG	Bulgaria	IT	Italy	PL	Poland
BJ	Benin	JP	Japan	PT	Portugal
BR	Brazil	KE	Kenya	RO	Romania
BY	Belarus	KG	Kyrgyzstan	RU	Russian Federation
CA	Canada	KP	Democratic People's Republic of Korea	SD	Sudan
CF	Central African Republic	KR	Republic of Korea	SE	Sweden
CG	Congo	KZ	Kazakhstan	SG	Singapore
CH	Switzerland	LI	Liechtenstein	SI	Slovenia
CI	Côte d'Ivoire	LK	Sri Lanka	SK	Slovakia
CM	Cameroon	LR	Liberia	SN	Senegal
CN	China	LT	Lithuania	SZ	Swaziland
CS	Czechoslovakia	LU	Luxembourg	TD	Chad
CZ	Czech Republic	LV	Latvia	TG	Togo
DE	Germany	MC	Monaco	TJ	Tajikistan
DK	Denmark	MD	Republic of Moldova	TT	Trinidad and Tobago
EE	Estonia	MG	Madagascar	UA	Ukraine
ES	Spain	ML	Mali	UG	Uganda
FI	Finland	MN	Mongolia	US	United States of America
FR	France	MR	Mauritania	UZ	Uzbekistan
GA	Gabon			VN	Viet Nam

Titl : Hydraulically actuatable expander.

Technical Field.

The invention relates to a hydraulically actuatable expander of the type described in the preamble of claim 1.

5 Background Art

DK-PS No. 160,578B discloses an apparatus for expanding an underground passageway, such as a sewer, or for removing irregularities therein while moving through said passageway. The known apparatus comprises an expandable, segmented section with a series of shell parts or shell
10 elements placed around a longitudinal axis on the apparatus, and with associated outwardly directed surface sections engaging the sides of the passageway. These shell parts are movable in the lateral direction relative to the longitudinal axis from a concentrated configuration to an expanded configuration in such a manner that they press against the side of the
15 passageway or the sewer. Furthermore, the apparatus comprises a nose part extending in the longitudinal axis in front of the segmented section and having an outer surface for the engagement with the sides of the passageway in front of the segmented section. This apparatus comprises a large number of interconnected bars serving to alternately expand the
20 segmented section and the nose part in such a manner that the sewer is expanded while the apparatus is allowed to pass through said sewer. The bars are moved by means of a hydraulic jack accommodated inside the apparatus, said jack being actuated in the longitudinal direction of the apparatus. Thus the apparatus can be forced through the sewer or the
25 pipeline by a repeated actuation of the hydraulic jack with the indicated positioning, said jack being alternately connected and disconnected at each stroke by means of a chain or a wire connected to the apparatus through the pipeline. While the apparatus is pulled through the pipeline, a

pipe liner of a corresponding diameter is simultaneously pulled after the apparatus through the pipeline. As a result, the pipeline is straightened and repaired.

DK Patent Application No. 285/88 discloses an apparatus of a corresponding nature which has been further developed such that no loose particles of material from the wall of the pipeline penetrate into the apparatus between the shell elements, said shell elements being shaped and arranged so as to overlap one another also during the expansion.

Brief Description of the Invention

10 The object of the present invention is to provide a hydraulically actuatable expander of the above type which possesses a very high expansion force, which avoids the problem of penetrating loose particles of material from the wall of the pipeline or the ground, and which is capable of leaving the straightened pipeline in a supported state in such a manner that it is ready
15 for a final repair or has been prepared for a specific repair prior to insertion of a new synthetic lining.

This object is according to the invention obtained by the hydraulically actuatable expander comprising the subject matter stated in the characterising clause of claim 1.

20 Brief Description of the Drawings

The invention is described in greater detail below with reference to the accompanying drawing illustrating an embodiment according to the invention, and in which

Fig. 1 is a longitudinal sectional view taken along the line A-A of Fig. 2 of
25 a hydraulically actuatable expander according to the invention,

Fig. 2 is a left end view of the expander of Fig. 1,

Fig. 3 is a right end view of the expander of Fig. 1,

Fig. 4 is a cross-sectional view taken along the line B-B through the
5 expander of Fig. 1,

Fig. 5 illustrates the same view as Fig. 4 when the expander enters an expanded state,

Fig. 6 is a cross-sectional view taken along the line C-C through the expander of Fig. 1,

10 Fig. 7 illustrates the same view as Fig. 6 when the expander enters an expanded state,

Fig. 8 illustrates on a larger scale the same view as Fig. 4,

Fig. 9 illustrates on a larger scale the same view as Fig. 5,

Fig. 10 illustrates on a larger scale the same view as Fig. 6,

15 Fig. 11 illustrates on a larger scale the same view as Fig. 7,

Fig. 12 is like Fig. 2 a left end view of the expander, but on a larger scale and with a flexible plate arranged around the expander and provided with overlapping edges and locking means adjacent said edges,

Fig. 13 illustrate the same view as Fig. 12 when the expander enters an
20 expanded state and the locking means at the two edges of the plate have entered a locking engagement with one another, and

Fig. 14 illustrates on a larger scale the area indicated by means of the circle D in Fig. 13 of the mutually engaging locking means.

Best Mode for Carrying Out the Invention

Fig. 1 illustrates a hydraulically actuatable expander according to the invention, but without the flexible plate which must be left in a
5 straightened pipeline. The expander 1 comprises an elongated cylinder housing 2, which in the illustrated embodiment is made of four interconnected modules assembled by means of through stay bolts, each end of said stay bolts being indicated by means of 3 and 4, respectively. Such a
10 module is shown with hatched lines immediately to the right of the sectional line B-B of Fig. 1. This module comprises three bores in each of the two sections succeeding one another in the longitudinal direction. The subsequent three modules are correspondingly structured. The elongated
cylinder housing 2 is thus made of these four modules, and in the illustrated
15 embodiment it is manufactured with a hexagonal surface 5 and a cylindrical longitudinal perforation 6, the axis of which coincides with the central longitudinal axis 7-7 of the expander.

The above bores are produced in a plane hexagonal side or surface 5 and are directed towards the central longitudinal axis. Thus a total of twenty-
20 four bores applies, and a cylinder sleeve 8 is inserted in each of these bores.

In the illustrated embodiment, the three cylinder sleeves 8 in a single section have been mutually staggered 120° , and the cylinder sleeves in a section have been staggered 60° relative to the cylinder sleeves of an
25 adjacent section. Instead of placing the cylinder sleeves 8 in the above bores in the cylinder housing 2, it is, of course, possible to manufacture a suitable cylinder bore allowing a direct insertion of a piston.

- The illustrated embodiment with cylinder sleeves 8 is such that a piston 9 is inserted in each sleeve. The piston surface of each piston 9 facing away from the longitudinal axis is secured on an expander segment 10 partially surrounding the cylinder housing 2. A total of six such expander segments 10 applies, each expander segment being circular in such a manner that in the assembled state of the of the expander 1 they abut one another completely or substantially along their edges extending in the longitudinal direction so as to form a closed cylindrical surface. Thus four pistons 9 are secured to each of the six expander segments 10, cf. in particular, Fig. 1.
- 10 The bores 6 allow a feeding of pressurised hydraulic oil to the piston surface facing the longitudinal axis in such a manner that said bore 6 forms part of a hydraulic pipeline for the feeding of said hydraulic oil pressure.

When hydraulic pressure is applied for expanding the pistons 9 and consequently the expander segments 10 secured to said pistons, the diameter of the cylinder formed by the expander segments is increased, as shown in Figs. 6 and 7 and on a larger scale in the corresponding Figs. 9 and 10. As a result, spaces 11 are formed between the longitudinal edges of the individual expander segments 10.

- 20 Now you can imagine that some of the expander segments 10 face less resistance than other segments from the collapsed pipeline into which the hydraulically actuatable expander is inserted so as to straighten and repair said pipeline. It is also possible to imagine that the resistance to the expansion of an expander segment 10 is stronger at one end of said expander segment than at the opposite end. Therefore a risk exists that the expander segments 10 are not always positioned on the same circular arc or that the expander does not maintain its circular-cylindrical shape, but becomes frusto-conical.

Therefore at least two synchronizing mechanisms are provided, cf. Fig. 4 showing the folded state of the expander and Fig. 5 showing the expanded state of said expander. The same synchronizing mechanisms are shown on a larger scale in Figs. 8 and 9, respectively. The synchronizing mechanism shown in Figs. 4, 5, and 8, 9 is as shown arranged at the sectional line B-B where the first module begins. A second corresponding synchronizing mechanism is arranged at the location where the last module ends in such a manner that the two synchronizing mechanisms are symmetrically arranged around the transverse centre of the expander.

Each synchronizing mechanism comprises a synchronizing disk 12 arranged coaxially with the central longitudinal axis of the expander. The synchronizing disk 12 is pivotally connected to each of the expander segments 10 or to a disk segment 13 secured thereto by means of respective synchronizing arms 14. The illustrated embodiment includes thus six synchronizing arms 14. One end of each synchronizing arm 14 is pivotally journalled on the synchronizing disk 12 at bearings 15 arranged at the same mutual angular distance, here 60° and at the same distance from the centre of the disk. The other end of the synchronizing arms 14 is pivotally journalled in bearings 16 in the respective disk segment 13 on each of the expander segments. As illustrated in the drawing, the synchronizing arms 14 are arranged alternately on one side and the opposite side of the synchronizing disk 12. It appears from Figs. 5 and 9, that when the expander expands the synchronizing disk 12 turns counter-clockwise, cf. Figs. 4, 5, 8, and 9.

It appears furthermore that the individual expander segments 10 are bound to expand in the same extent all the time.

As stated above, the expander 1 comprises at least one additional synchronizing mechanism of a completely identical structure. The synchronizing mechanisms are interconnected by means of a shaft 17 extending in

the central longitudinal axis of the expander through a central opening in each of the synchronizing disks 12 and being secured thereto by means of keyway connections 18. As a result, the synchronizing disks 12 interconnected by means of the shaft 17 are forced to turn the same number of degrees counterclockwise during the expansion of the expander. Therefore the expander segments are expanded to the same extent opposite each of the two synchronizing mechanisms, and consequently the expander maintains its circular-cylindrical shape during the entire expansion irrespective of whether it faces more resistance at some areas than at other areas.

10 As illustrated in Figs. 12 and 13, a flexible plate 19 with overlapping edges 20 and 21 is arranged around the expander 1. This plate extends in the entire longitudinal direction of the expander and covers thus both the expander segments 10 and the spaces 11 resulting between said expander segments 10 when the expander 1 expands. The plate 19 is preferably a
15 stainless rolled plate, but it can, of course, also be a plate of any other material, such as plastics. Locking means 22 and 23, respectively, are provided adjacent each of the overlapping edges 20, 21 of the plate, cf. Figs. 12 and 13. The locking means 22 and 23 are adapted to automatically enter a locking engagement when the desired straightening of the
20 pipeline has been completed. When the expander has expanded to such an extent that the pipeline has been straightened, the two locking means 22 and 23 arranged on their respective sides of the plate 19 meet and position themselves atop one another as shown in Figs. 13 and more clearly in Fig. 14. The locking means 22, 23 can for instance as it is known be grooves
25 and projections, respectively, in the surface of the plate 19, but it is according to the invention preferred that said locking means are provided in form of a strong dual lock traded under the Trade Mark Dual Lock.

It turned out that locking means 22, 23 of this type are highly suitable for maintaining the plate 19 in the expanded state after the expander has
30 been caused to contract so that it can be removed from the location in

question inside the pipeline. Thus the plate 19 forms a plate cylinder supporting the damaged, but straightened pipeline when the expander 1 contracts and is removed. Long pipelines can be straightened by repeating the process, and the inserted plate cylinders 19 can be used for the final
5 repair or as preparation for a local repair prior to the insertion of a new plastic lining into a pipeline.

All the illustrated twenty-four piston cylinder arrangements are of the same type for practical reasons because they are double-acting. As a result, they can all assist in the active withdrawal of the expander from
10 the expanded state. It is, of course, obvious that the expander segments or some of said expander segments may be of a single-effect type. The feeding of the pressurized hydraulic oil is as stated above performed through the bore 6 while the supply of oil pressure for the returning of the pistons 9 is performed through channels 24 in the cylinder housing. As
15 shown in Fig. 10, this hydraulic pressure acts on the opposite side 25 of each piston.

When cylinder sleeves 8 are used for surrounding the pistons 9 it is obvious that it is easy to replace these cylinder sleeves 8 by other cylinder sleeves in such a manner that it is possible to obtain a larger stroke and
20 accordingly to use the expander for straightening pipelines of a larger diameter.

Claims

1. A hydraulically actuatable expander for straightening and repairing partially collapsed pipelines by way of an insertion therein and with a flexible plate with overlapping edges arranged around the expander, as well as locking means adjacent each overlapping edge of the plate, said locking means automatically entering a locking engagement when the desired straightening of the pipeline has been obtained, c h a r a c -
t e r i s e d in that the expander comprises:
- at least one elongated cylinder housing with a central longitudinal axis and
one or a plurality of cylinder bores or cylinder sleeves in a single section transverse to said longitudinal axis,
- a piston inserted in each cylinder bore or each cylinder sleeve, whereby the piston surface of said piston facing away from the longitudinal axis is secured on an expander segment partially surrounded by the cylinder housing, and where the piston surface facing the longitudinal axis communicates with a hydraulic channel for the supply of hydraulic pressure for the expansion of the pistons and consequently of the expander segments secured thereto, said expander segments together surrounding the cylinder housing, wherein the flexible plate continuously covers the expander segments and the spaces therebetween during the expansion, and
- at least two synchronizing mechanisms arranged at regular intervals in the longitudinal direction of the cylinder housing and being connected to the expander segments in such a manner that all said expander segments expand synchronously to the same extent, where said two synchronizing mechanisms furthermore are interconnected such that the expander segments also expand to the same extent at the position of one synchronizing mechanism as at the position of the second synchronizing mechanism.

2. Expander as claimed in claim 1, characterized in that it comprises several cylinder bores or cylinder sleeves in a common section of the cylinder housing, said cylinder bores or said cylinder sleeves being arranged at a regular angular distance.
- 5 3. Expander as claimed in claim 1 or 2, characterized in that the cylinder housing comprises several sections succeeding one another in the longitudinal direction of said cylinder housing, said sections forming a module.
4. Expander as claimed in claim 3, characterized in that the
10 cylinder housing is made of several interconnected modules.
5. Expander as claimed in claims 2 to 4, characterized in that it comprises four modules, each modules comprising two sections with three cylinder sleeves provided with their respective pistons.
6. Expander as claimed in claims 1 to 5, characterized in that it
15 comprises two synchronizing mechanisms, each synchronizing mechanism being provided with a synchronizing disk pivotally connected to each expander segment by means of a plurality of synchronizing arms, where one end of said synchronizing arms is pivotally connected to the synchronizing disk and the opposite end is pivotally connected to an expander
20 segment, whereby the synchronizing disks of said two synchronizing mechanisms are permanently interconnected by means of a shaft extending in the central longitudinal axis of the expanding.
7. Expander as claimed in claims 1 to 6, characterized in that the flexible plate is a rolled steel plate.
- 25 8. Expander as claimed in claim 7, characterized in that the

locking means adjacent each of the overlapping edges of the plate are formed by a dual lock, such as a Dual Lock.

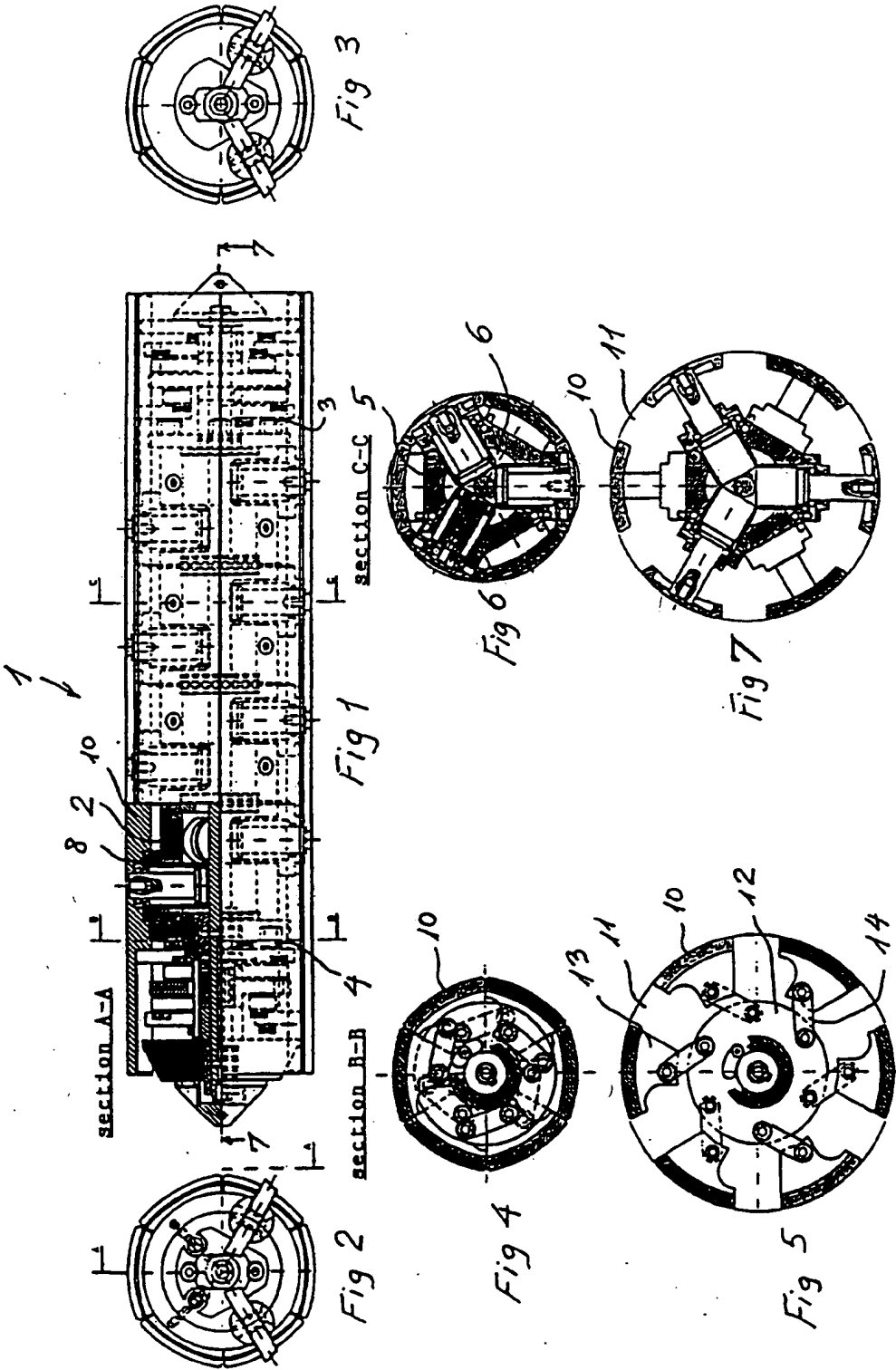

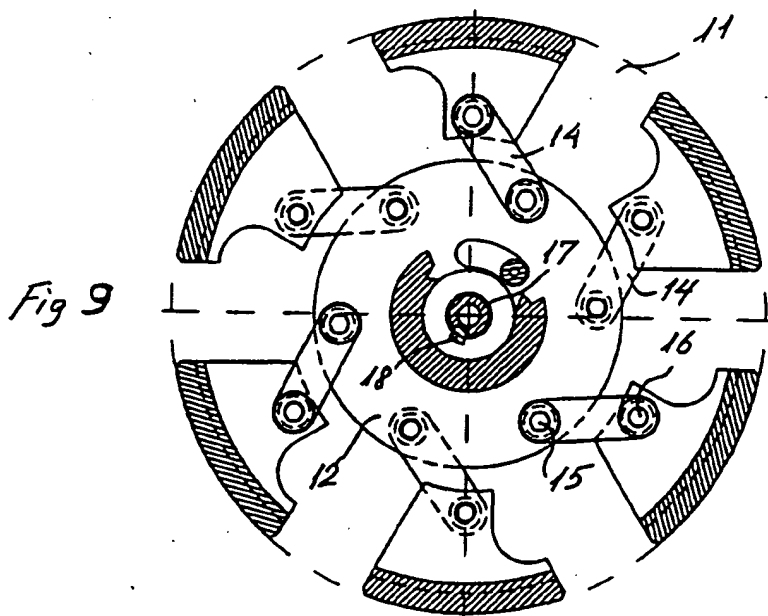
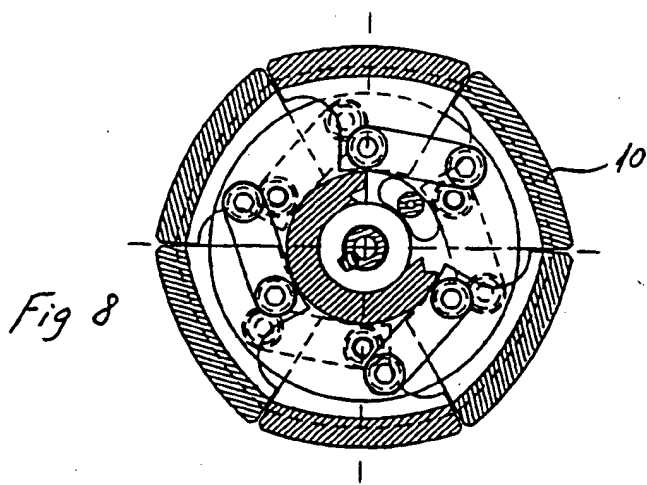

3/4

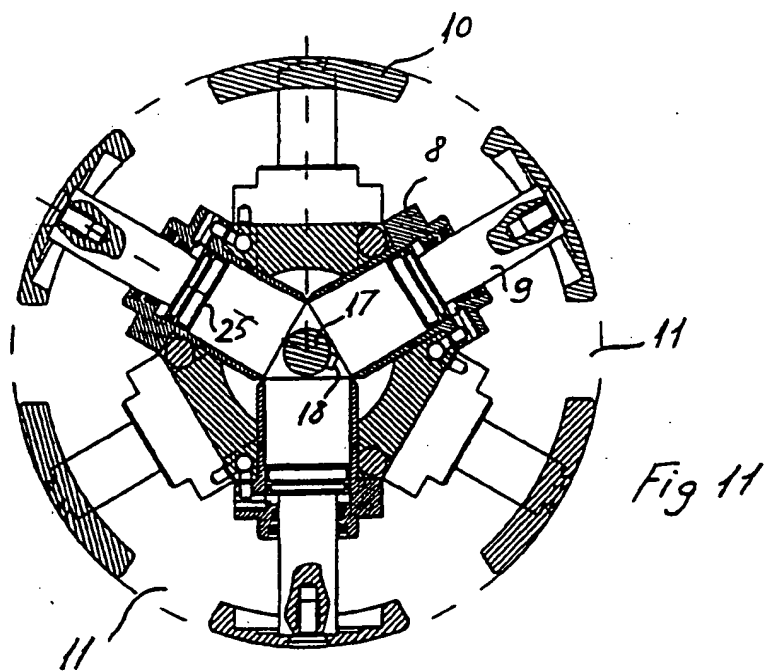
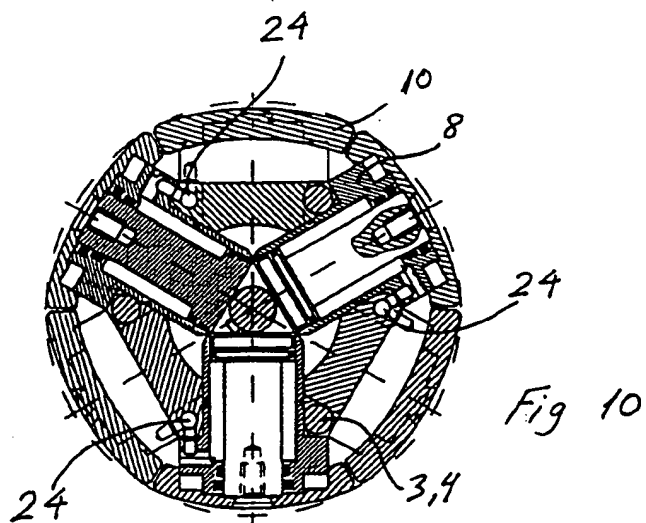

INTERNATIONAL SEARCH REPORT

International application No.
PCT/DK 96/00393

A. CLASSIFICATION OF SUBJECT MATTER		
IPC6: F16L 55/165 According to International Patent Classification (IPC) or to both national classification and IPC		
B. FIELDS SEARCHED		
Minimum documentation searched (classification system followed by classification symbols)		
IPC6: F16L		
Documentation searched other than minimum documentation to the extent that such documents are included in the fields searched		
SE,DK,FI,NO classes as above		
Electronic data base consulted during the international search (name of data base and, where practicable, search terms used)		
C. DOCUMENTS CONSIDERED TO BE RELEVANT		
Category*	Citation of document, with indication, where appropriate, of the relevant passages	Relevant to claim No.
A	EP 0060715 A1 (MAIMETS, LEMBIT), 22 Sept 1982 (22.09.82), page 14, line 8 - page 15, line 11 --	1-8
A	WO 8810393 A1 (WESTMAN, S.), 29 December 1988 (29.12.88), figures 3a,3b, abstract --	1-6
A	EP 0324287 A1 (BRITISH GAS PLC), 19 July 1989 (19.07.89), claim 1, abstract. --	1-6
A	DE 4410900 A1 (HAAS, H.), 8 June 1995 (08.06.95), figures 1,3 -- -----	7-8
<input type="checkbox"/> Further documents are listed in the continuation of Box C. <input checked="" type="checkbox"/> See patent family annex.		
<p>* Special categories of cited documents</p> <p>"A" document defining the general state of the art which is not considered to be of particular relevance</p> <p>"E" earlier document but published on or after the international filing date</p> <p>"L" document which may throw doubt on priority claim(s) or which is cited to establish the publication date of another citation or other special reason (as specified)</p> <p>"O" document referring to an oral disclosure, use, exhibition or other means</p> <p>"P" document published prior to the international filing date but later than the priority date claimed</p> <p>"T" later document published after the international filing date or priority date and not in conflict with the application but cited to understand the principle or theory underlying the invention</p> <p>"X" document of particular relevance: the claimed invention cannot be considered novel or cannot be considered to involve an inventive step when the document is taken alone</p> <p>"Y" document of particular relevance: the claimed invention cannot be considered to involve an inventive step when the document is combined with one or more other such documents, such combination being obvious to a person skilled in the art</p> <p>"Z" document number of the same patent family</p>		
Date of the actual completion of the international search		Date of mailing of the international search report
2 December 1996		14 -12- 1996
Name and mailing address of the ISA/ Swedish Patent Office Box 5055, S-102 42 STOCKHOLM Facsimile No. +46 8 666 02 86		Authorized officer Tommy Blomberg Telephone No. +46 8 782 25 00

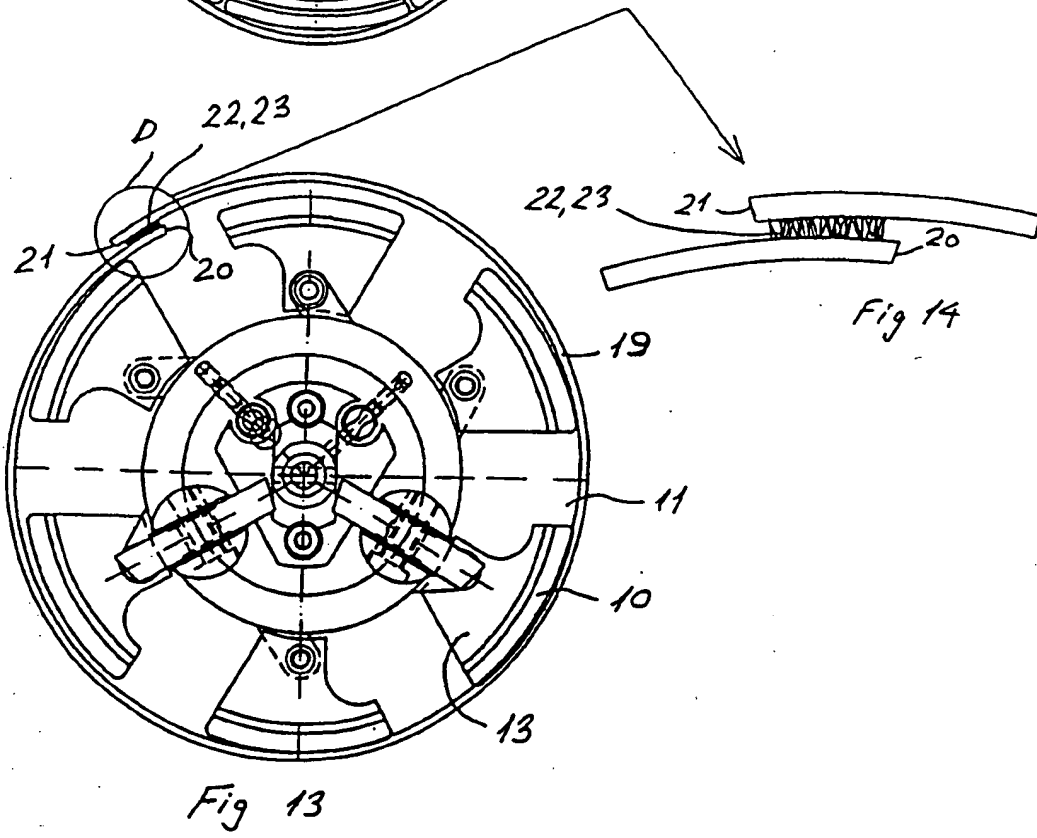
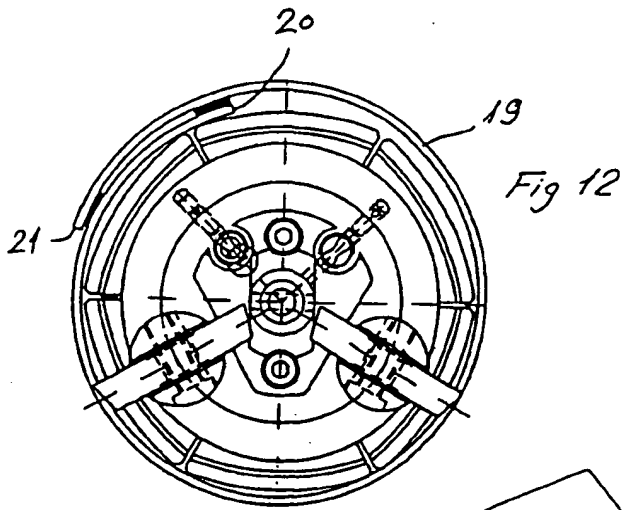

INTERNATIONAL SEARCH REPORT
 Information on patent family members

28/10/96

International application No.

PCT/DK 96/00393

Patent document cited in search report	Publication date	Patent family member(s)	Publication date
EP-A1- 0060715	22/09/82	SE-T3- 0060715	
		AU-A- 8558382	22/09/83
		GB-A- 2101262	12/01/83
WO-A1- 8810393	29/12/88	AU-A- 1960088	19/01/89
		EP-A- 0363424	18/04/90
		SE-D- 8702543	00/00/00
		US-A- 5056269	15/10/91
EP-A1- 0324287	19/07/89	AU-A- 2770789	13/07/89
		CA-A- 1290318	08/10/91
		GB-A- 2214260	31/08/89
		JP-A- 2003790	09/01/90
		JP-B- 7076513	16/08/95
		US-A- 4928866	29/05/90
DE-A1- 4410900	08/06/95	AU-A- 7992294	19/06/95
		DE-U- 9417247	06/04/95
		WO-A- 9515460	08/06/95

PCT

WORLD INTELLECTUAL PROPERTY ORGANIZATION
International Bureau



INTERNATIONAL APPLICATION PUBLISHED UNDER THE PATENT COOPERATION TREATY (PCT)

<p>(51) International Patent Classification ⁶ : F16L 55/165</p>	<p>A1</p>	<p>(11) International Publication Number: WO 97/11306 (43) International Publication Date: 27 March 1997 (27.03.97)</p>
<p>(21) International Application Number: PCT/DK96/00393 (22) International Filing Date: 18 September 1996 (18.09.96) (30) Priority Data: 1039/95 19 September 1995 (19.09.95) DK (71)(72) Applicant and Inventor: KNUDSEN, Jens, Christian, Haugaard (DK/DK); Lokesvej 19, DK-3140 Ålsgårde (DK). (74) Agent: CHAS. HUDE A/S; H.C. Andersen Boulevard 33, DK-1553 Copenhagen V (DK).</p>	<p>(81) Designated States: AL, AM, AT, AU, AZ, BA, BB, BG, BR, BY, CA, CH, CN, CU, CZ, DE, DK, EE, ES, FI, GB, GE, HU, IL, IS, JP, KE, KG, KP, KR, KZ, LC, LK, LR, LS, LT, LU, LV, MD, MG, MK, MN, MW, MX, NO, NZ, PL, PT, RO, RU, SD, SE, SG, SI, SK, TJ, TM, TR, TT, UA, UG, US, UZ, VN, ARIPO patent (KE, LS, MW, SD, SZ, UG), Eurasian patent (AM, AZ, BY, KG, KZ, MD, RU, TJ, TM), European patent (AT, BE, CH, DE, DK, ES, FI, FR, GB, GR, IE, IT, LU, MC, NL, PT, SE), OAPI patent (BF, BJ, CF, CG, CI, CM, GA, GN, ML, MR, NE, SN, TD, TG).</p> <p>Published With international search report.</p>	

(54) Title: HYDRAULICALLY ACTUATABLE EXPANDER

(57) Abstract

The invention relates to a hydraulically actuatable expander (1) for straightening and repairing partially collapsed pipelines. In order to obtain a high straightening force, it comprises: at least one elongated cylinder housing (2) with a central longitudinal axis (7-7) and one or a plurality of cylinder bores or cylinder sleeves (8) in a single section transverse to said longitudinal axis (7-7); a piston inserted in each cylinder bore or each cylinder sleeve (8), said piston being connected to a hydraulic channel for the expansion of expander segments (10) secured thereto, at least two synchronizing mechanisms arranged at regular intervals in the longitudinal direction of the cylinder housing and being connected to the expander segments (10) in such a manner that all said expander segments expand synchronously to the same extent, where said two synchronizing mechanisms furthermore are interconnected such that the expander segments (10) also expand to the same extent at the position of one synchronizing mechanism as at the position of the second synchronizing mechanism.

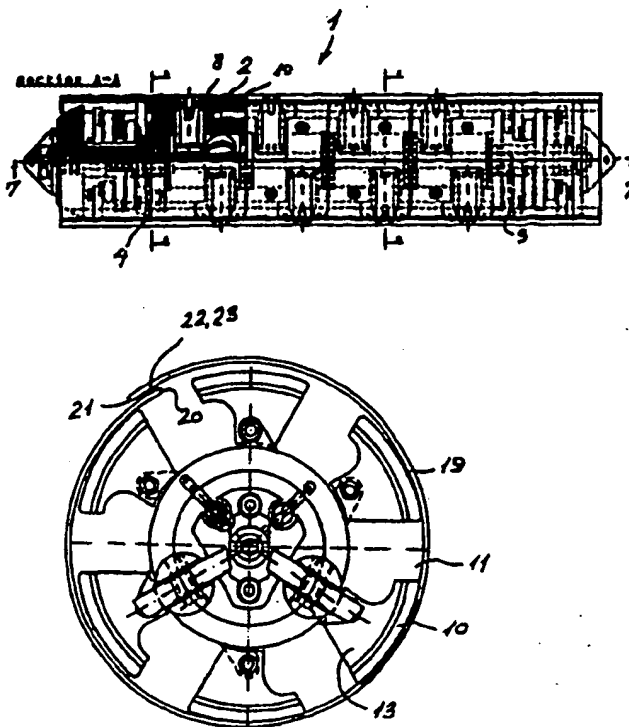

FOR THE PURPOSES OF INFORMATION ONLY

Codes used to identify States party to the PCT on the front pages of pamphlets publishing international applications under the PCT.

AM	Armenia	GB	United Kingdom	MW	Malawi
AT	Austria	GE	Georgia	MX	Mexico
AU	Australia	GN	Gabon	NE	Niger
BB	Barbados	GR	Greece	NL	Netherlands
BE	Belgium	HU	Hungary	NO	Norway
BF	Burkina Faso	IE	Ireland	NZ	New Zealand
BG	Bulgaria	IT	Italy	PL	Poland
BJ	Benin	JP	Japan	PT	Portugal
BR	Brazil	KE	Kenya	RO	Romania
BY	Belarus	KG	Kyrgyzstan	RU	Russian Federation
CA	Canada	KP	Democratic People's Republic of Korea	SD	Sudan
CF	Central African Republic	KR	Republic of Korea	SE	Sweden
CG	Congo	KZ	Kazakhstan	SG	Singapore
CH	Switzerland	LI	Liechtenstein	SI	Slovenia
CI	Côte d'Ivoire	LK	Sri Lanka	SK	Slovakia
CM	Cameroon	LR	Liberia	SN	Senegal
CN	China	LT	Lithuania	SE	Switzerland
CS	Czechoslovakia	LU	Luxembourg	TD	Chad
CZ	Czech Republic	LV	Latvia	TG	Togo
DE	Germany	MC	Monaco	TJ	Tajikistan
DK	Denmark	MD	Republic of Moldova	TT	Trinidad and Tobago
EE	Estonia	MG	Madagascar	UA	Ukraine
ES	Spain	ML	Mali	UG	Uganda
FI	Finland	MN	Mongolia	US	United States of America
FR	France	MR	Mauritania	UZ	Uzbekistan
GA	Gabon			VN	Viet Nam

Title: Hydraulically actuatable expander.

Technical Field.

The invention relates to a hydraulically actuatable expander of the type described in the preamble of claim 1.

5 Background Art

DK-PS No. 160,578B discloses an apparatus for expanding an underground passageway, such as a sewer, or for removing irregularities therein while moving through said passageway. The known apparatus comprises an expandable, segmented section with a series of shell parts or shell
10 elements placed around a longitudinal axis on the apparatus, and with associated outwardly directed surface sections engaging the sides of the passageway. These shell parts are movable in the lateral direction relative to the longitudinal axis from a concentrated configuration to an expanded configuration in such a manner that they press against the side of the
15 passageway or the sewer. Furthermore, the apparatus comprises a nose part extending in the longitudinal axis in front of the segmented section and having an outer surface for the engagement with the sides of the passageway in front of the segmented section. This apparatus comprises a large number of interconnected bars serving to alternately expand the
20 segmented section and the nose part in such a manner that the sewer is expanded while the apparatus is allowed to pass through said sewer. The bars are moved by means of a hydraulic jack accommodated inside the apparatus, said jack being actuated in the longitudinal direction of the apparatus. Thus the apparatus can be forced through the sewer or the
25 pipeline by a repeated actuation of the hydraulic jack with the indicated positioning, said jack being alternately connected and disconnected at each stroke by means of a chain or a wire connected to the apparatus through the pipeline. While the apparatus is pulled through the pipeline, a

pipe liner of a corresponding diameter is simultaneously pulled after the apparatus through the pipeline. As a result, the pipeline is straightened and repaired.

DK Patent Application No. 285/88 discloses an apparatus of a corresponding nature which has been further developed such that no loose particles of material from the wall of the pipeline penetrate into the apparatus between the shell elements, said shell elements being shaped and arranged so as to overlap one another also during the expansion.

Brief Description of the Invention

10 The object of the present invention is to provide a hydraulically actuatable expander of the above type which possesses a very high expansion force, which avoids the problem of penetrating loose particles of material from the wall of the pipeline or the ground, and which is capable of leaving the straightened pipeline in a supported state in such a manner that it is ready
15 for a final repair or has been prepared for a specific repair prior to insertion of a new synthetic lining.

This object is according to the invention obtained by the hydraulically actuatable expander comprising the subject matter stated in the characterising clause of claim 1.

20 Brief Description of the Drawings

The invention is described in greater detail below with reference to the accompanying drawing illustrating an embodiment according to the invention, and in which

Fig. 1 is a longitudinal sectional view taken along the line A-A of Fig. 2 of
25 a hydraulically actuatable expander according to the invention,

Fig. 2 is a left end view of the expander of Fig. 1,

Fig. 3 is a right end view of the expander of Fig. 1,

Fig. 4 is a cross-sectional view taken along the line B-B through the
5 expander of Fig. 1,

Fig. 5 illustrates the same view as Fig. 4 when the expander enters an
expanded state,

Fig. 6 is a cross-sectional view taken along the line C-C through the
expander of Fig. 1,

10 Fig. 7 illustrates the same view as Fig. 6 when the expander enters an
expanded state,

Fig. 8 illustrates on a larger scale the same view as Fig. 4,

Fig. 9 illustrates on a larger scale the same view as Fig. 5,

Fig. 10 illustrates on a larger scale the same view as Fig. 6,

15 Fig. 11 illustrates on a larger scale the same view as Fig. 7,

Fig. 12 is like Fig. 2 a left end view of the expander, but on a larger scale
and with a flexible plate arranged around the expander and provided with
overlapping edges and locking means adjacent said edges,

Fig. 13 illustrate the same view as Fig. 12 when the expander enters an
20 expanded state and the locking means at the two edges of the plate have
entered a locking engagement with one another, and

Fig. 14 illustrates on a larger scale the area indicated by means of the circle D in Fig. 13 of the mutually engaging locking means.

Best Mode for Carrying Out the Invention

Fig. 1 illustrates a hydraulically actuatable expander according to the invention, but without the flexible plate which must be left in a straightened pipeline. The expander 1 comprises an elongated cylinder housing 2, which in the illustrated embodiment is made of four interconnected modules assembled by means of through stay bolts, each end of said stay bolts being indicated by means of 3 and 4, respectively. Such a module is shown with hatched lines immediately to the right of the sectional line B-B of Fig. 1. This module comprises three bores in each of the two sections succeeding one another in the longitudinal direction. The subsequent three modules are correspondingly structured. The elongated cylinder housing 2 is thus made of these four modules, and in the illustrated embodiment it is manufactured with a hexagonal surface 5 and a cylindrical longitudinal perforation 6, the axis of which coincides with the central longitudinal axis 7-7 of the expander.

The above bores are produced in a plane hexagonal side or surface 5 and are directed towards the central longitudinal axis. Thus a total of twenty-four bores applies, and a cylinder sleeve 8 is inserted in each of these bores.

In the illustrated embodiment, the three cylinder sleeves 8 in a single section have been mutually staggered 120° , and the cylinder sleeves in a section have been staggered 60° relative to the cylinder sleeves of an adjacent section. Instead of placing the cylinder sleeves 8 in the above bores in the cylinder housing 2, it is, of course, possible to manufacture a suitable cylinder bore allowing a direct insertion of a piston.

The illustrated embodiment with cylinder sleeves 8 is such that a piston 9 is inserted in each sleeve. The piston surface of each piston 9 facing away from the longitudinal axis is secured on an expander segment 10 partially surrounding the cylinder housing 2. A total of six such expander segments 10 applies, each expander segment being circular in such a manner that in the assembled state of the of the expander 1 they abut one another completely or substantially along their edges extending in the longitudinal direction so as to form a closed cylindrical surface. Thus four pistons 9 are secured to each of the six expander segments 10, cf. in particular, Fig. 1.

10 The bores 6 allow a feeding of pressurised hydraulic oil to the piston surface facing the longitudinal axis in such a manner that said bore 6 forms part of a hydraulic pipeline for the feeding of said hydraulic oil pressure.

When hydraulic pressure is applied for expanding the pistons 9 and consequently the expander segments 10 secured to said pistons, the diameter of the cylinder formed by the expander segments is increased, as shown in Figs. 6 and 7 and on a larger scale in the corresponding Figs. 9 and 10. As a result, spaces 11 are formed between the longitudinal edges of the individual expander segments 10.

20 Now you can imagine that some of the expander segments 10 face less resistance than other segments from the collapsed pipeline into which the hydraulically actuatable expander is inserted so as to straighten and repair said pipeline. It is also possible to image that the resistance to the expansion of an expander segment 10 is stronger at one end of said expander segment than at the opposite end. Therefore a risk exists that the expander segments 10 are not always positioned on the same circular arc or that the expander does not maintain its circular-cylindrical shape, but becomes frusto-conical.

Therefore at least two synchronizing mechanisms are provided, cf. Fig. 4 showing the folded state of the expander and Fig. 5 showing the expanded state of said expander. The same synchronizing mechanisms are shown on a larger scale in Figs. 8 and 9, respectively. The synchronizing mechanism shown in Figs. 4, 5, and 8, 9 is as shown arranged at the sectional line B-B where the first module begins. A second corresponding synchronizing mechanism is arranged at the location where the last module ends in such a manner that the two synchronizing mechanisms are symmetrically arranged around the transverse centre of the expander.

Each synchronizing mechanism comprises a synchronizing disk 12 arranged coaxially with the central longitudinal axis of the expander. The synchronizing disk 12 is pivotally connected to each of the expander segments 10 or to a disk segment 13 secured thereto by means of respective synchronizing arms 14. The illustrated embodiment includes thus six synchronizing arms 14. One end of each synchronizing arm 14 is pivotally journalled on the synchronizing disk 12 at bearings 15 arranged at the same mutual angular distance, here 60° and at the same distance from the centre of the disk. The other end of the synchronizing arms 14 is pivotally journalled in bearings 16 in the respective disk segment 13 on each of the expander segments. As illustrated in the drawing, the synchronizing arms 14 are arranged alternately on one side and the opposite side of the synchronizing disk 12. It appears from Figs. 5 and 9, that when the expander expands the synchronizing disk 12 turns counter-clockwise, cf. Figs. 4, 5, 8, and 9.

It appears furthermore that the individual expander segments 10 are bound to expand in the same extent all the time.

As stated above, the expander 1 comprises at least one additional synchronizing mechanism of a completely identical structure. The synchronizing mechanisms are interconnected by means of a shaft 17 extending in

the central longitudinal axis of the expander through a central opening in each of the synchronizing disks 12 and being secured thereto by means of keyway connections 18. As a result, the synchronizing disks 12 interconnected by means of the shaft 17 are forced to turn the same number of
5 degrees counterclockwise during the expansion of the expander. Therefore the expander segments are expanded to the same extent opposite each of the two synchronizing mechanisms, and consequently the expander maintains its circular-cylindrical shape during the entire expansion irrespective of whether it faces more resistance at some areas than at other areas.

10 As illustrated in Figs. 12 and 13, a flexible plate 19 with overlapping edges 20 and 21 is arranged around the expander 1. This plate extends in the entire longitudinal direction of the expander and covers thus both the expander segments 10 and the spaces 11 resulting between said expander segments 10 when the expander 1 expands. The plate 19 is preferably a
15 stainless rolled plate, but it can, of course, also be a plate of any other material, such as plastics. Locking means 22 and 23, respectively, are provided adjacent each of the overlapping edges 20, 21 of the plate, cf. Figs. 12 and 13. The locking means 22 and 23 are adapted to automatically enter a locking engagement when the desired straightening of the
20 pipeline has been completed. When the expander has expanded to such an extent that the pipeline has been straightened, the two locking means 22 and 23 arranged on their respective sides of the plate 19 meet and position themselves atop one another as shown in Figs. 13 and more clearly in Fig. 14. The locking means 22, 23 can for instance as it is known be grooves
25 and projections, respectively, in the surface of the plate 19, but it is according to the invention preferred that said locking means are provided in form of a strong dual lock traded under the Trade Mark Dual Lock.

It turned out that locking means 22, 23 of this type are highly suitable for maintaining the plate 19 in the expanded state after the expander has
30 been caused to contract so that it can be removed from the location in

question inside the pipeline. Thus the plate 19 forms a plate cylinder supporting the damaged, but straightened pipeline when the expander 1 contracts and is removed. Long pipelines can be straightened by repeating the process, and the inserted plate cylinders 19 can be used for the final
5 repair or as preparation for a local repair prior to the insertion of a new plastic lining into a pipeline.

All the illustrated twenty-four piston cylinder arrangements are of the same type for practical reasons because they are double-acting. As a result, they can all assist in the active withdrawal of the expander from
10 the expanded state. It is, of course, obvious that the expander segments or some of said expander segments may be of a single-effect type. The feeding of the pressurized hydraulic oil is as stated above performed through the bore 6 while the supply of oil pressure for the returning of the pistons 9 is performed through channels 24 in the cylinder housing. As
15 shown in Fig. 10, this hydraulic pressure acts on the opposite side 25 of each piston.

When cylinder sleeves 8 are used for surrounding the pistons 9 it is obvious that it is easy to replace these cylinder sleeves 8 by other cylinder sleeves in such a manner that it is possible to obtain a larger stroke and
20 accordingly to use the expander for straightening pipelines of a larger diameter.

Claims

1. A hydraulically actuatable expander for straightening and repairing partially collapsed pipelines by way of an insertion therein and with a flexible plate with overlapping edges arranged around the expander, as well as locking means adjacent each overlapping edge of the plate, said locking means automatically entering a locking engagement when the desired straightening of the pipeline has been obtained, c h a r a c -
t e r i s e d in that the expander comprises:
- at least one elongated cylinder housing with a central longitudinal axis and
one or a plurality of cylinder bores or cylinder sleeves in a single section transverse to said longitudinal axis,
- a piston inserted in each cylinder bore or each cylinder sleeve, whereby the piston surface of said piston facing away from the longitudinal axis is secured on an expander segment partially surrounded by the cylinder housing, and where the piston surface facing the longitudinal axis communicates with a hydraulic channel for the supply of hydraulic pressure for the expansion of the pistons and consequently of the expander segments secured thereto, said expander segments together surrounding the cylinder housing, wherein the flexible plate continuously covers the expander segments and the spaces therebetween during the expansion, and
- at least two synchronizing mechanisms arranged at regular intervals in the longitudinal direction of the cylinder housing and being connected to the expander segments in such a manner that all said expander segments expand synchronously to the same extent, where said two synchronizing mechanisms furthermore are interconnected such that the expander segments also expand to the same extent at the position of one synchronizing mechanism as at the position of the second synchronizing mechanism.

2. Expander as claimed in claim 1, characterized in that it comprises several cylinder bores or cylinder sleeves in a common section of the cylinder housing, said cylinder bores or said cylinder sleeves being arranged at a regular angular distance.
- 5 3. Expander as claimed in claim 1 or 2, characterized in that the cylinder housing comprises several sections succeeding one another in the longitudinal direction of said cylinder housing, said sections forming a module.
4. Expander as claimed in claim 3, characterized in that the
10 cylinder housing is made of several interconnected modules.
5. Expander as claimed in claims 2 to 4, characterized in that it comprises four modules, each modules comprising two sections with three cylinder sleeves provided with their respective pistons.
6. Expander as claimed in claims 1 to 5, characterized in that it
15 comprises two synchronizing mechanisms, each synchronizing mechanism being provided with a synchronizing disk pivotally connected to each expander segment by means of a plurality of synchronizing arms, where one end of said synchronizing arms is pivotally connected to the synchronizing disk and the opposite end is pivotally connected to an expander
20 segment, whereby the synchronizing disks of said two synchronizing mechanisms are permanently interconnected by means of a shaft extending in the central longitudinal axis of the expanding.
7. Expander as claimed in claims 1 to 6, characterized in that the flexible plate is a rolled steel plate.
- 25 8. Expander as claimed in claim 7, characterized in that the

locking means adjacent each of the overlapping edges of the plate are formed by a dual lock, such as a Dual Lock.

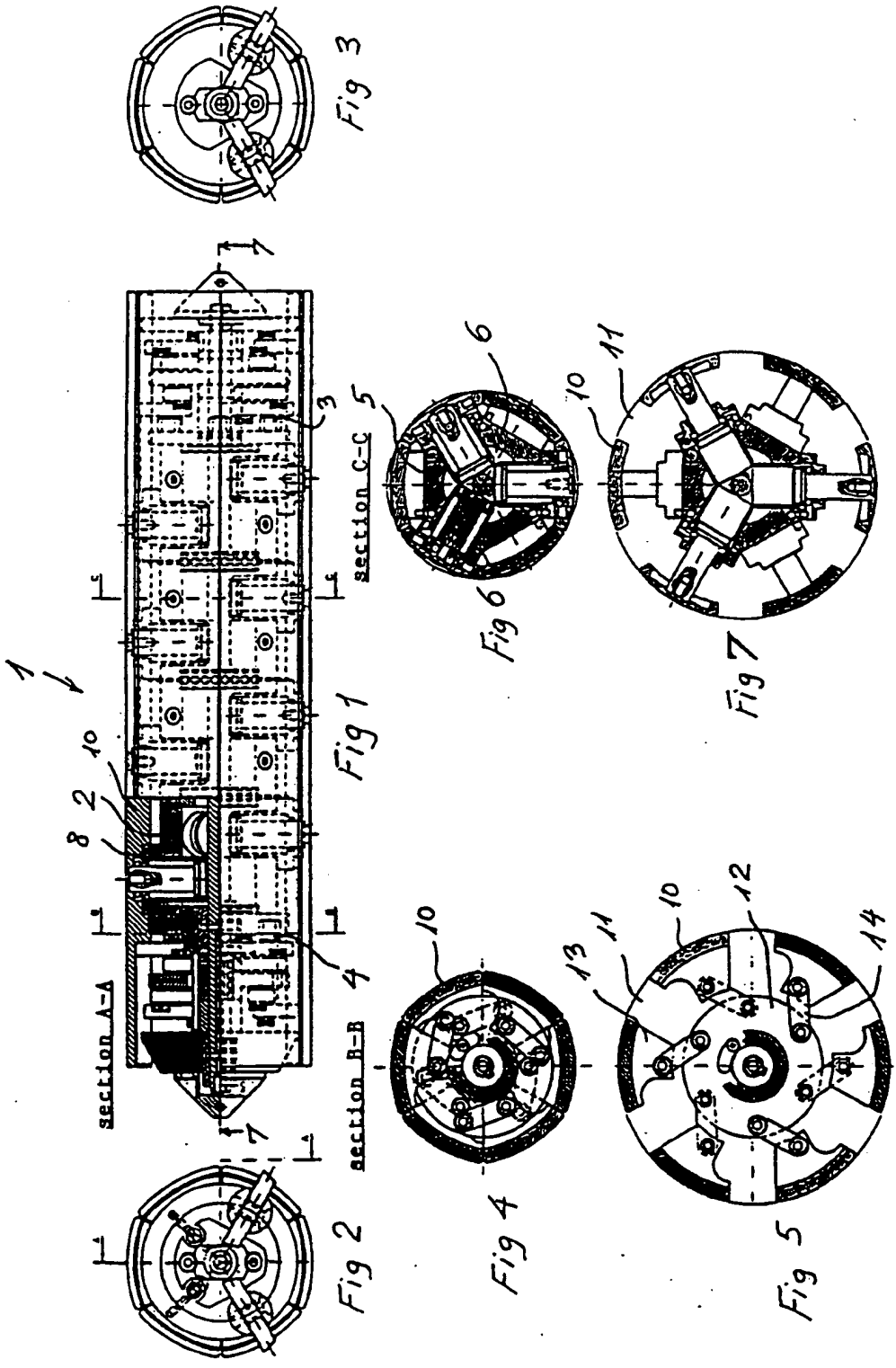

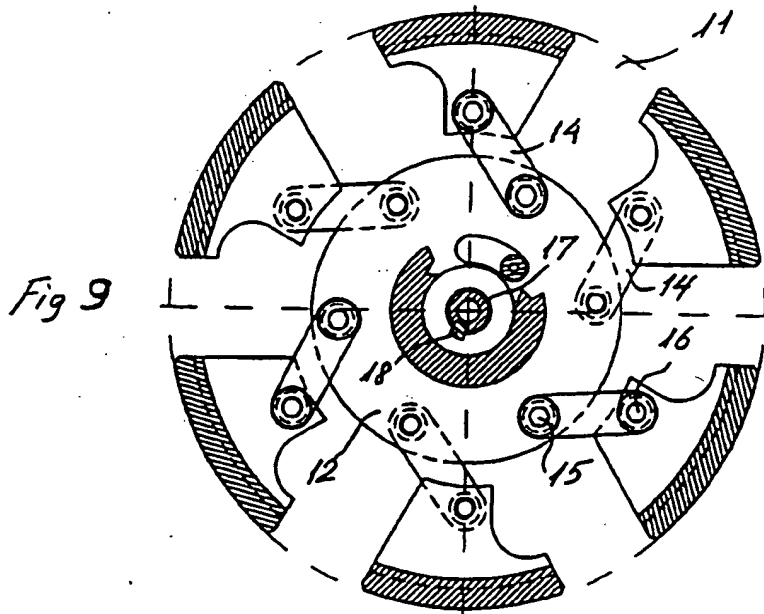
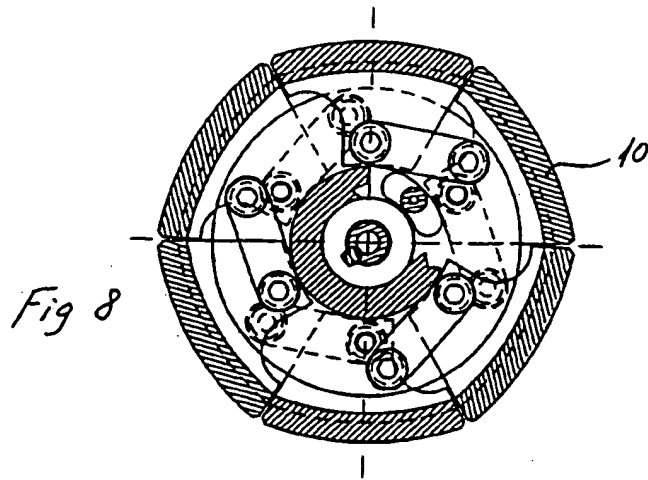

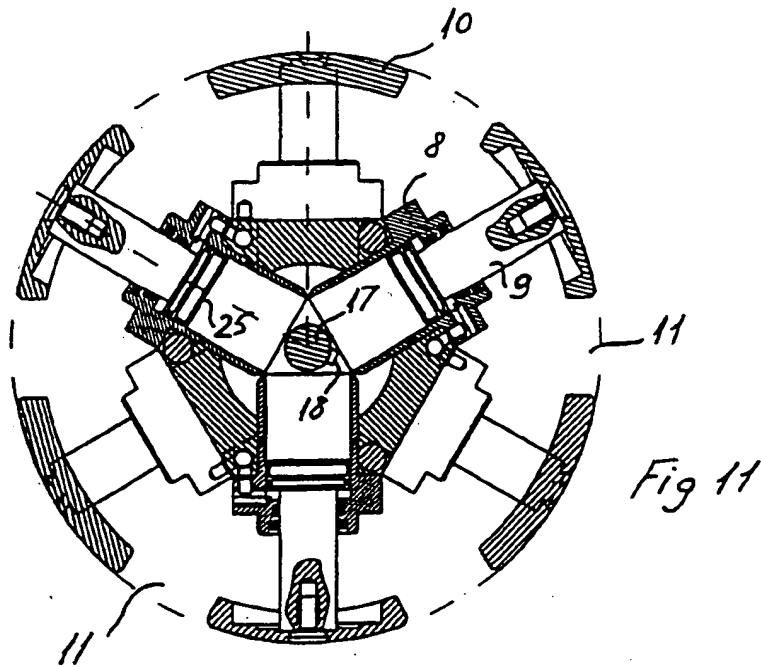
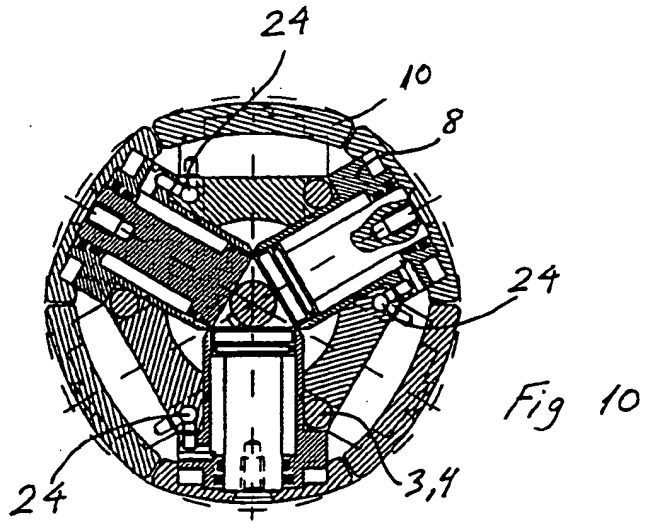

INTERNATIONAL SEARCH REPORT

International application No.

PCT/DK 96/00393

A. CLASSIFICATION OF SUBJECT MATTER		
IPC6: F16L 55/165 According to International Patent Classification (IPC) or to both national classification and IPC		
B. FIELDS SEARCHED		
Minimum documentation searched (classification system followed by classification symbols)		
IPC6: F16L		
Documentation searched other than minimum documentation to the extent that such documents are included in the fields searched		
SE,DK,FI,NO classes as above		
Electronic data base consulted during the international search (name of data base and, where practicable, search terms used)		
C. DOCUMENTS CONSIDERED TO BE RELEVANT		
Category*	Citation of document, with indication, where appropriate, of the relevant passages	Relevant to claim No.
A	EP 0060715 A1 (MAIMETS, LEMBIT), 22 Sept 1982 (22.09.82), page 14, line 8 - page 15, line 11 --	1-8
A	WO 8810393 A1 (WESTMAN, S.), 29 December 1988 (29.12.88), figures 3a,3b, abstract --	1-6
A	EP 0324287 A1 (BRITISH GAS PLC), 19 July 1989 (19.07.89), claim 1, abstract. --	1-6
A	DE 4410900 A1 (HAAS, H.), 8 June 1995 (08.06.95), figures 1,3 -- -----	7-8
<input type="checkbox"/> Further documents are listed in the continuation of Box C. <input checked="" type="checkbox"/> See patent family annex.		
* Special categories of cited documents: *A* document defining the general state of the art which is not considered to be of particular relevance *B* earlier document but published on or after the international filing date *L* document which may throw doubts on priority claim(s) or which is cited to establish the publication date of another citation or other special reason (as specified) *O* document referring to an oral disclosure, use, exhibition or other means *P* document published prior to the international filing date but later than the priority date claimed *T* later document published after the international filing date or priority date and not in conflict with the application but cited to underpin the principle or theory underlying the invention *X* document of particular relevance: the claimed invention cannot be considered novel or cannot be considered to involve an inventive step when the document is taken alone *Y* document of particular relevance: the claimed invention cannot be considered to involve an inventive step when the document is combined with one or more other such documents, such combination being obvious to a person skilled in the art *Z* document member of the same patent family		
Date of the actual completion of the international search		Date of mailing of the international search report
2 December 1996		14 -12- 1996
Name and mailing address of the ISA/ Swedish Patent Office Box 5055, S-102 42 STOCKHOLM Facsimile No. +46 8 666 02 86		Authorized officer Tommy Blomberg Telephone No. +46 8 782 25 00

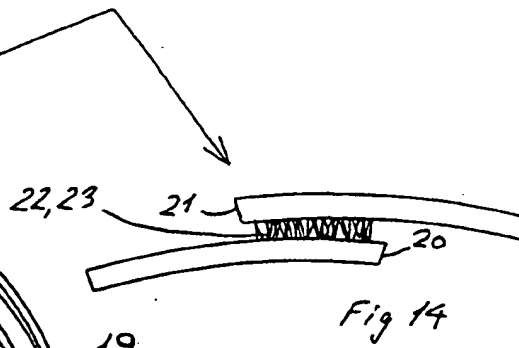
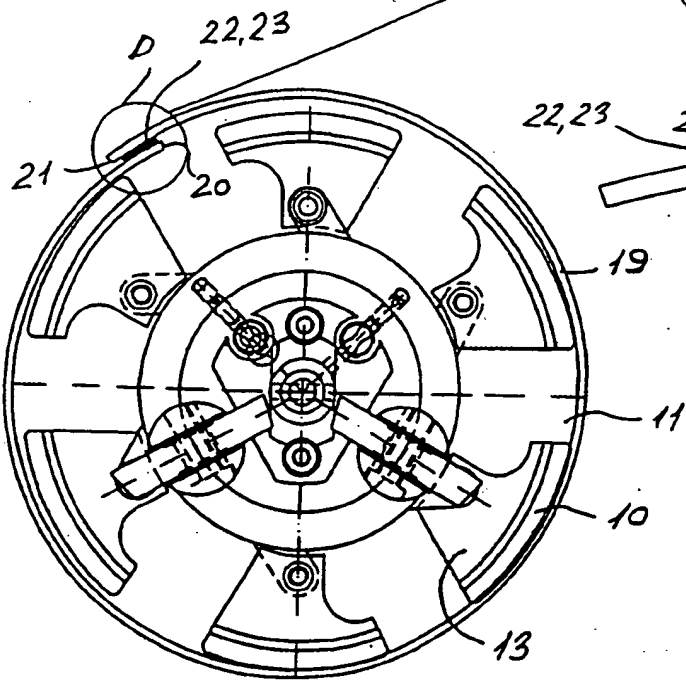
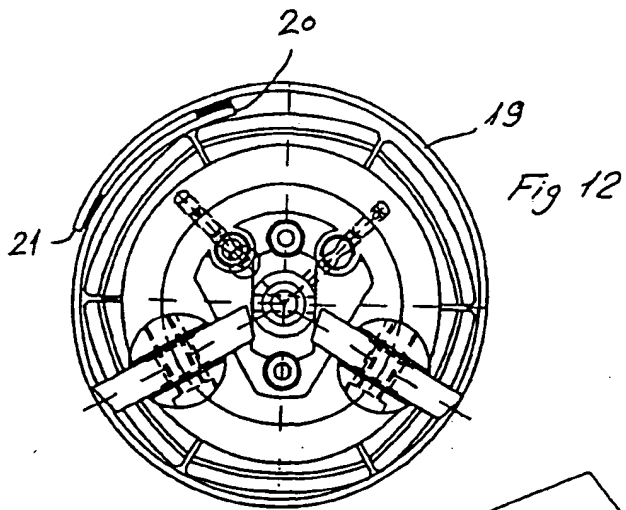

Fig 13

Fig 14

INTERNATIONAL SEARCH REPORT
Information on patent family members

28/10/96

International application No.
PCT/DK 96/00393

Patent document cited in search report	Publication date	Patent family member(s)	Publication date
EP-A1- 0060715	22/09/82	SE-T3- 0060715	
		AU-A- 8558382	22/09/83
		GB-A- 2101262	12/01/83
WO-A1- 8810393	29/12/88	AU-A- 1960088	19/01/89
		EP-A- 0363424	18/04/90
		SE-D- 8702543	00/00/00
		US-A- 5056269	15/10/91
EP-A1- 0324287	19/07/89	AU-A- 2770789	13/07/89
		CA-A- 1290318	08/10/91
		GB-A- 2214260	31/08/89
		JP-A- 2003790	09/01/90
		JP-B- 7076513	16/08/95
		US-A- 4928866	29/05/90
DE-A1- 4410900	08/06/95	AU-A- 7992294	19/06/95
		DE-U- 9417247	06/04/95
		WO-A- 9515460	08/06/95